

## MSM6309

---

### SOLID STATE RECORDING LSI (FOR 256K-bit SRAM)

---

#### GENERAL DESCRIPTION

The MSM6309 is a solid-state recording LSI developed using the ADPCM (Adaptive Differential Pulse Code Modulation) technology. When an external microphone, speaker driv-

ing amplifier, speaker and a 256K-bit SRAM to store ADPCM data are connected to the MSM6309, it can be used to record and play back voice or other sounds in the manner similar to that of a tape recorder.

#### FEATURES

- 4-bit ADPCM technology
- Built-in 8-bit AD converter
- Built-in 8-bit DA converter
- Built-in microphone pre-amplifier
- Built-in low-pass filter
- One 256K-bit SRAM (MSM51257) can be directly driven
- Sampling frequencies:  
4.0 and 8.0 kHz (when the oscillator operates at 4.096 MHz)
- Oscillator frequencies:  
4 to 6 MHz
- Number of words to be recorded:  
One, two, or four words can be selected
- Maximum recording time:  
16 sec (when the sampling frequency is 4 kHz)
- Power supply voltage:  
5V only
- 60 pin plastic QFP (QFP60-P-1519-K)
- 60 pin-V plastic QFP (QFP60-P-1519-VK)

**PIN LAYOUT**

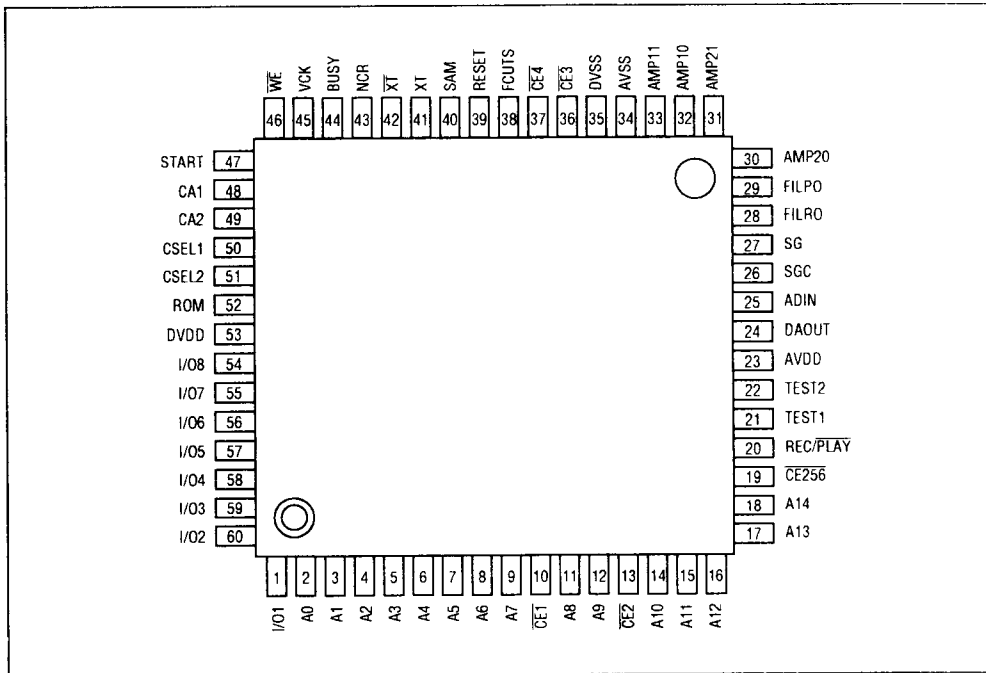

**CIRCUIT DIAGRAM**

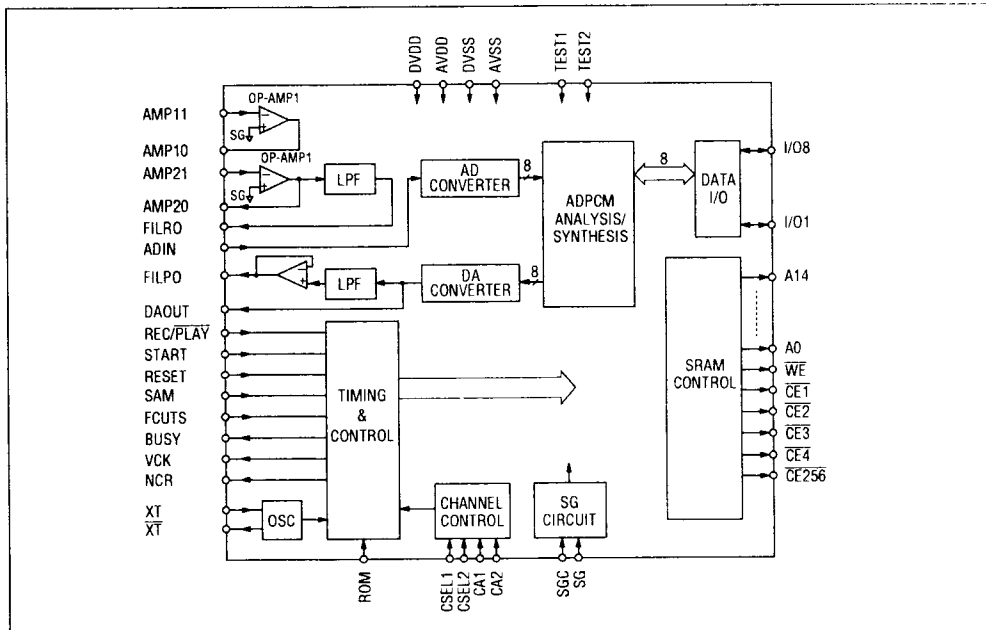

## ELECTRICAL CHARACTERISTICS

## ABSOLUTE MAXIMUM RATINGS

Parameter	Symbol	Condition	Rating	Unit
Power supply voltage	$V_{DD}$	$T_a = 25^\circ\text{C}$	-0.3 ~ 7.0	V
Input voltage	$V_{IN}$	$T_a = 25^\circ\text{C}$	-0.3 ~ $V_{DD} + 0.3$	V
Storage temperature range	$T_{stg}$	-	-55 ~ +150	$^\circ\text{C}$

## OPERATING RANGE

Parameter	Symbol	Condition	Rating	Unit
Power supply voltage	$V_{DD}$	$DVSS = AVSS = 0V$	+4.0 ~ +6.0	V
Operating temperature range	$T_{OP}$	-	-40 ~ +85	$^\circ\text{C}$
Oscillator frequency	$f_{osc}$	-	4.0 ~ 6.0	MHz

## DC ELECTRICAL CHARACTERISTICS

$$V_{DD} = 4.5\sim 5.5V \quad DVSS = AVSS = 0V \quad T_a = -40\sim +85^\circ\text{C}$$

Parameter	Symbol	Condition	Min.	Typ.	Max.	Unit
High Input Voltage (Note 1)	$V_{IH1}$	-	3.6	-	-	V
High Input Voltage (Note 2)	$V_{IH2}$	-	$0.8 \times V_{DD}$	-	-	V
Low Input Voltage	$V_{IL}$	-	-	-	0.8	V
High Output Voltage	$V_{OH}$	$I_{OH} = -40\mu\text{A}$	4.2	-	-	V
Low Output Voltage	$V_{OL}$	$I_{OL} = 2\text{mA}$	-	-	0.45	V
High Input Current	$I_{IH}$	$V_{IH} = V_{DD}$	-	-	10	$\mu\text{A}$
Low input Current	$I_{IL}$	$V_{IL} = V_{SS}$	-10	-	-	$\mu\text{A}$
Operating Consumed Current (1)	$I_{DD}$	$f_{osc} = 4.0\text{MHz}$ Under no load and without signals	-	3	6	mA
Operating Consumed Current (2)	$I_{DS}$	$f_{osc} = 4.0\text{MHz}$	-	2	4	mA
Operating Consumed Current (3)	$I_{PD}$	RESET = "H"	-	0.1	10	$\mu\text{A}$

**Note 1:** Applies to the input pins excluding pin XT.

**Note 2:** Applies to pin XT.

**ANALOG CHARACTERISTICS**

AD converter, DA converter, operational amplifier 1, and operational amplifier 2

$$V_{DD}=4.5\text{-}5.5\text{V} \quad DVSS=AVSS=0\text{V} \quad T_a=-40\text{-}+85^\circ\text{C}$$

Parameter	Symbol	Condition	Min.	Typ.	Max.	Unit
Relative DA output precision	$ V_{DAE} $	No load	-	-	60	mV
DA output impedance	$R_{DA}$	-	-	10	-	k $\Omega$
Relative AD conversion precision	$ V_{ADE} $	-	-	-	60	mV
AD conversion relative precision in 1/2 VDD point	$ V_{ADE2} $	-	-	-	150	mV
ADIN input voltage	$V_{AD}$	-	0	-	AVDD	V
Amplifier open loop gain	$G_{OP}$	-	-	-	40	dB
Amplifier input impedance	$R_{INA}$	-	-	100	-	M $\Omega$
Amplifier load resistance	$R_{OUTA}$	-	200	-	-	k $\Omega$
Allowable amplifier input voltage range	$V_{INA}$	-	-	-	$0.7 \times V_{DD}$	$V_{P-P}$
Amplifier output amplitude voltage range	$V_{OUTA}$	-	-	-	$0.7 \times V_{DD}$	$V_{P-P}$
Low-pass filter input impedance	$R_{IN}$	-	-	30	-	M $\Omega$
Low-pass filter load resistance	$R_{OUT}$	FILPO pin	50	-	-	k $\Omega$
Optimum low-pass filter input voltage range	$V_{IN}$	-	-	$0.6 \times V_{DD}$	-	$V_{P-P}$

## AC ELECTRICAL CHARACTERISTICS

$$f_{OSC} = 4.096\text{MHz}, f_{SAMP} = 8.0\text{kHz}$$

$$V_{DD} = 4.5\sim 5.5\text{V}, DVSS = AVSS = 0\text{V}, T_a = -40\sim +85^\circ\text{C}$$

Parameter	Symbol	Min.	Typ.	Max.	Unit
Start pulse width	$t_{STP}$	2	–	–	$\mu\text{S}$
Time beginning when REC/PLAY is switched and ending when START is input	$t_{RAS}$	0	–	–	$\mu\text{S}$
Hold time beginning when BUSY goes low and ending when REC/PLAY is switched	$t_{RSS}$	35	–	–	$\mu\text{S}$
Time beginning when START is input and ending when BUSY goes high *	$t_{SBR}$	45	–	55	$\mu\text{S}$
Time beginning when BUSY goes high and ending when NCR goes low *	$t_{BNF}$	–	188	–	$\mu\text{S}$
Width while NCR is kept low *	$t_{NCW}$	–	188	–	$\mu\text{S}$
Setup time of CA1 or CA2 for the NCR falling edge	$t_{CAS}$	2	–	–	$\mu\text{S}$
Hold time of CA1 or CA2 for the BCR falling edge	$t_{CAH}$	2	–	–	$\mu\text{S}$
Setup time of CSEL1 or CSEL2 for the NCR falling edge	$t_{CSS}$	2	–	–	$\mu\text{S}$
Hold time of CSEL1 or CSEL2 for the BUSY falling edge	$t_{CSH}$	0	–	–	$\mu\text{S}$
Time beginning when BUSY goes high and ending when recording starts *	$t_{BA}$	–	250	–	$\mu\text{S}$
Time beginning when START goes low and ending when recording ends *	$t_{SAR}$	30	–	200	$\mu\text{S}$
Time beginning when recording ends and ending when BUSY GOES LOW *	$t_{AB}$	–	500	–	$\mu\text{S}$
Time beginning when BUSY goes high and ending when playback starts *	$t_{BS}$	–	500	–	$\mu\text{S}$
Time beginning when playback completes and ending when BUSY goes low *	$t_{SB}$	–	313	–	$\mu\text{S}$
Hold time of START for the NCR falling edge during repetitive playback *	$t_{STH}$	0	–	–	$\mu\text{S}$
Time beginning when playback of the previous word completes and ending when NCR goes low during repetitive playback *	$t_{MNF}$	–	250	–	$\mu\text{S}$
Time during which no sound is heard between a word and the next word during repetitive playback *	$t_{MS}$	–	563	–	$\mu\text{S}$
Time during which VCK is kept high *	$t_{VH}$	–	62.5	–	$\mu\text{S}$
Time during which VCK is kept low *	$t_{VL}$	–	62.5	–	$\mu\text{S}$

## AC ELECTRICAL CHARACTERISTICS (Continued)

Parameter	Symbol	Min.	Typ.	Max.	Unit
Time from rising edge of VCK at recording and falling edge of $\overline{WE}$	$t_{VWF}$	–	39.1	–	$\mu\text{S}$
Pulse amplitude of $\overline{WE}$ at recording	$t_{WW}$	–	11.7	–	$\mu\text{S}$
High-order data setup time at recording	$t_{DSH}$	–	19.5	–	$\mu\text{S}$
Low-order data setup time at recording	$t_{DSL}$	–	114.5	–	$\mu\text{S}$
Write recovery time at recording	$t_{WR}$	–	7.8	–	$\mu\text{S}$
Time from the rising edge of VCK at playback and address countup	$t_{CU}$	–	58.6	–	$\mu\text{S}$

\*: When the sampling frequency is 4kHz, the time is doubled.

1. RECORDING

1-1 When the recording process is stopped before the capacity of the channel is exhausted

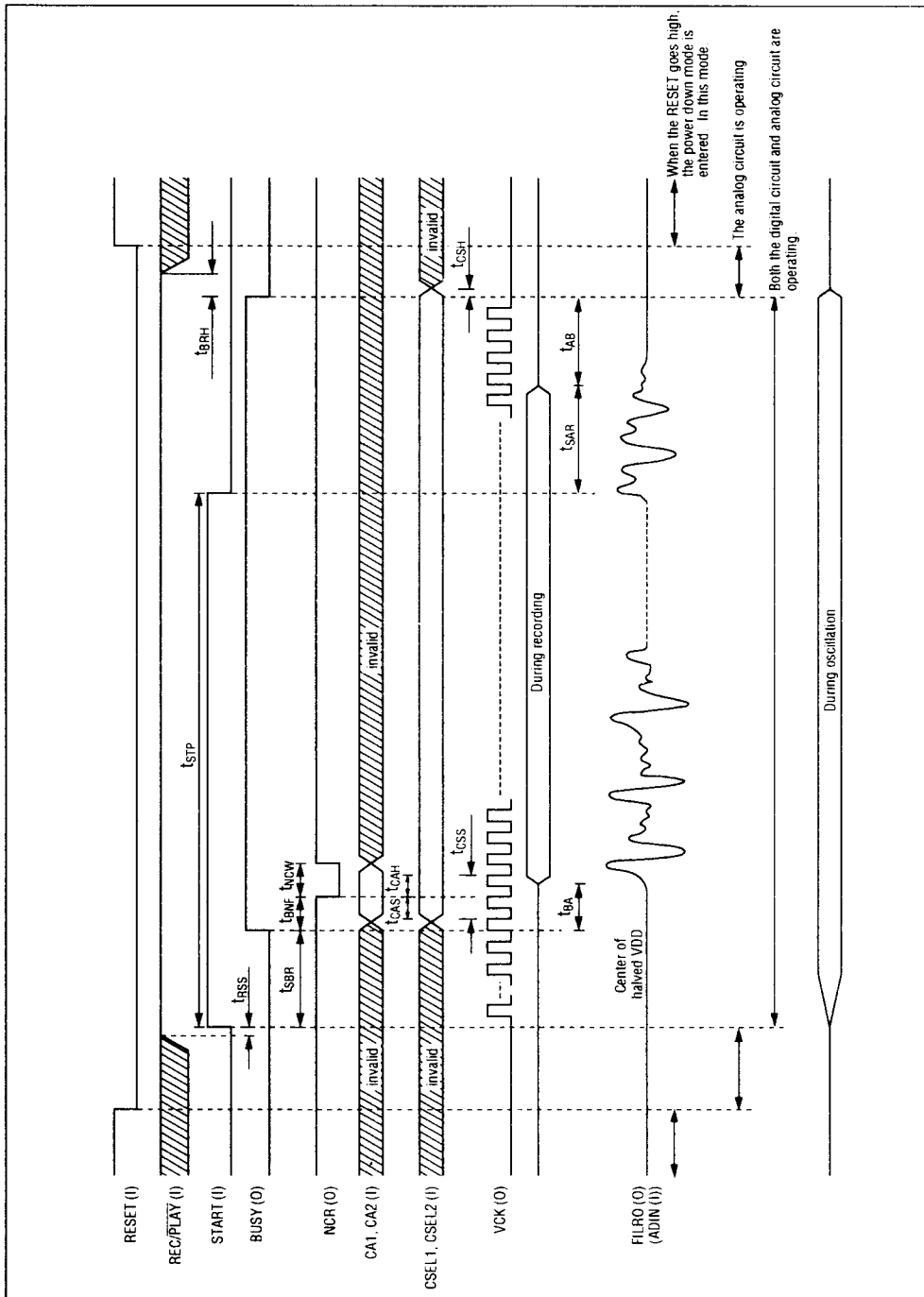

1-2 When the recording process is continued until the capacity of the channel is exhausted

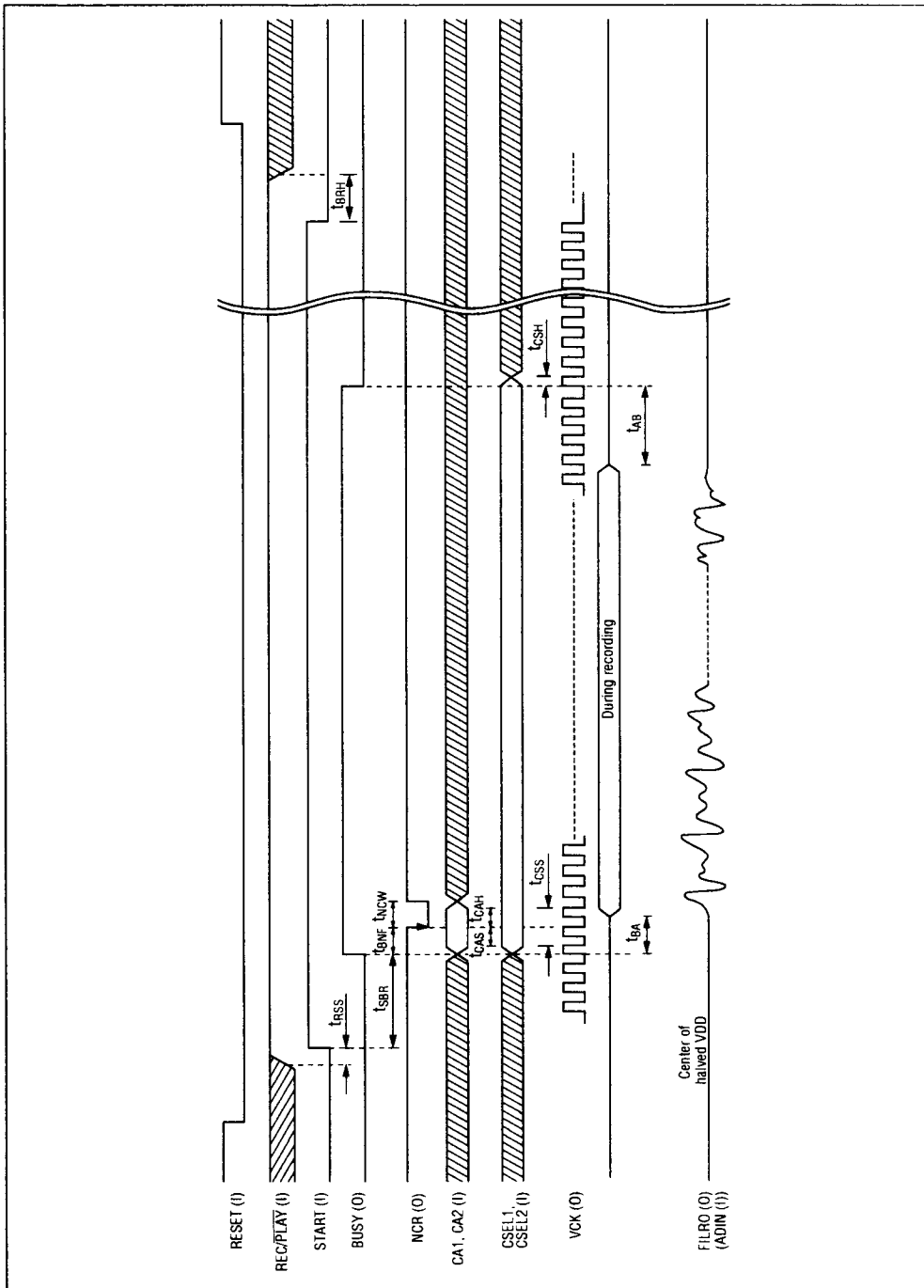



2. PLAYBACK

2-1 When playback is performed only once

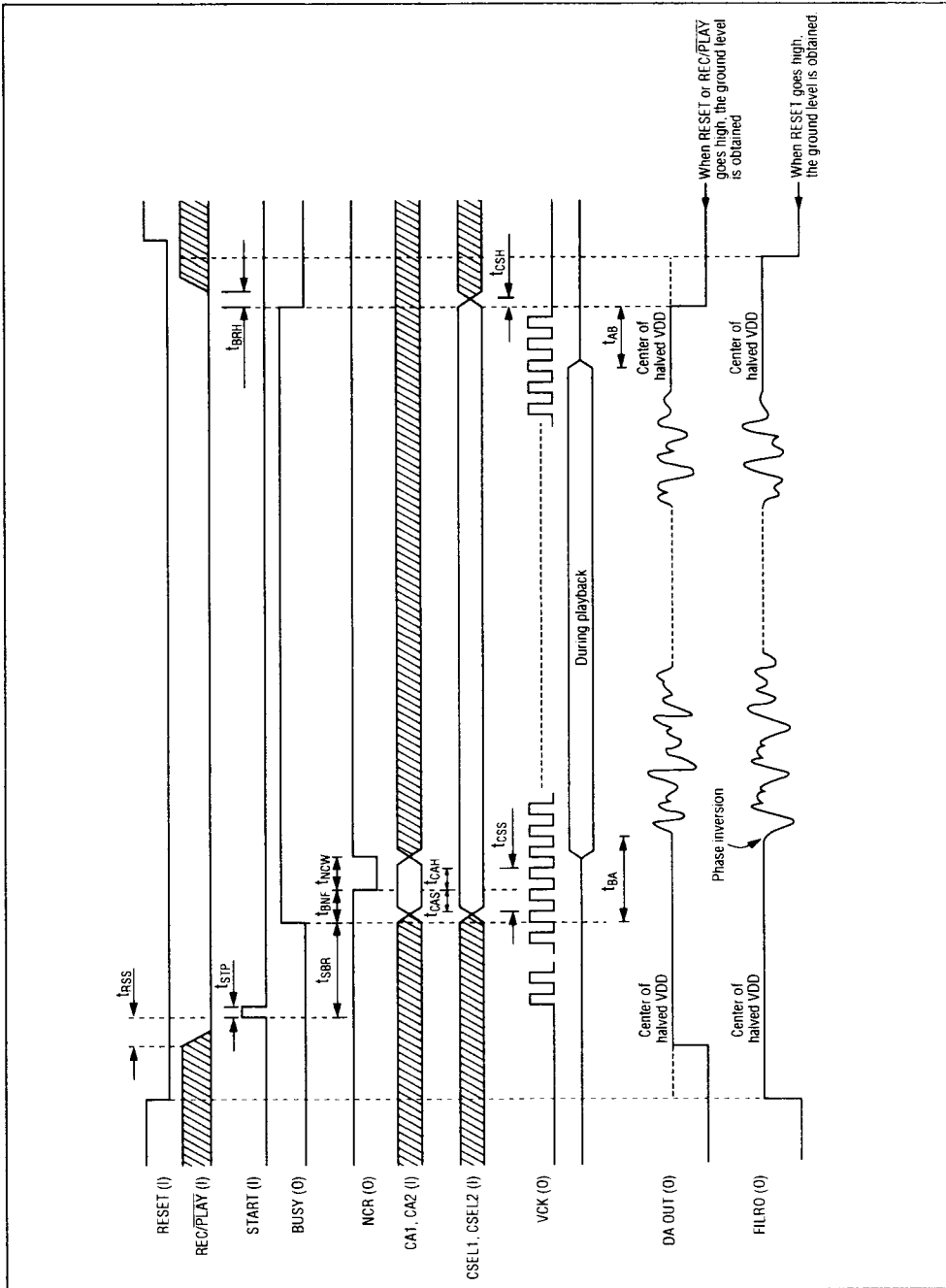

2-2 When playback is performed repeatedly

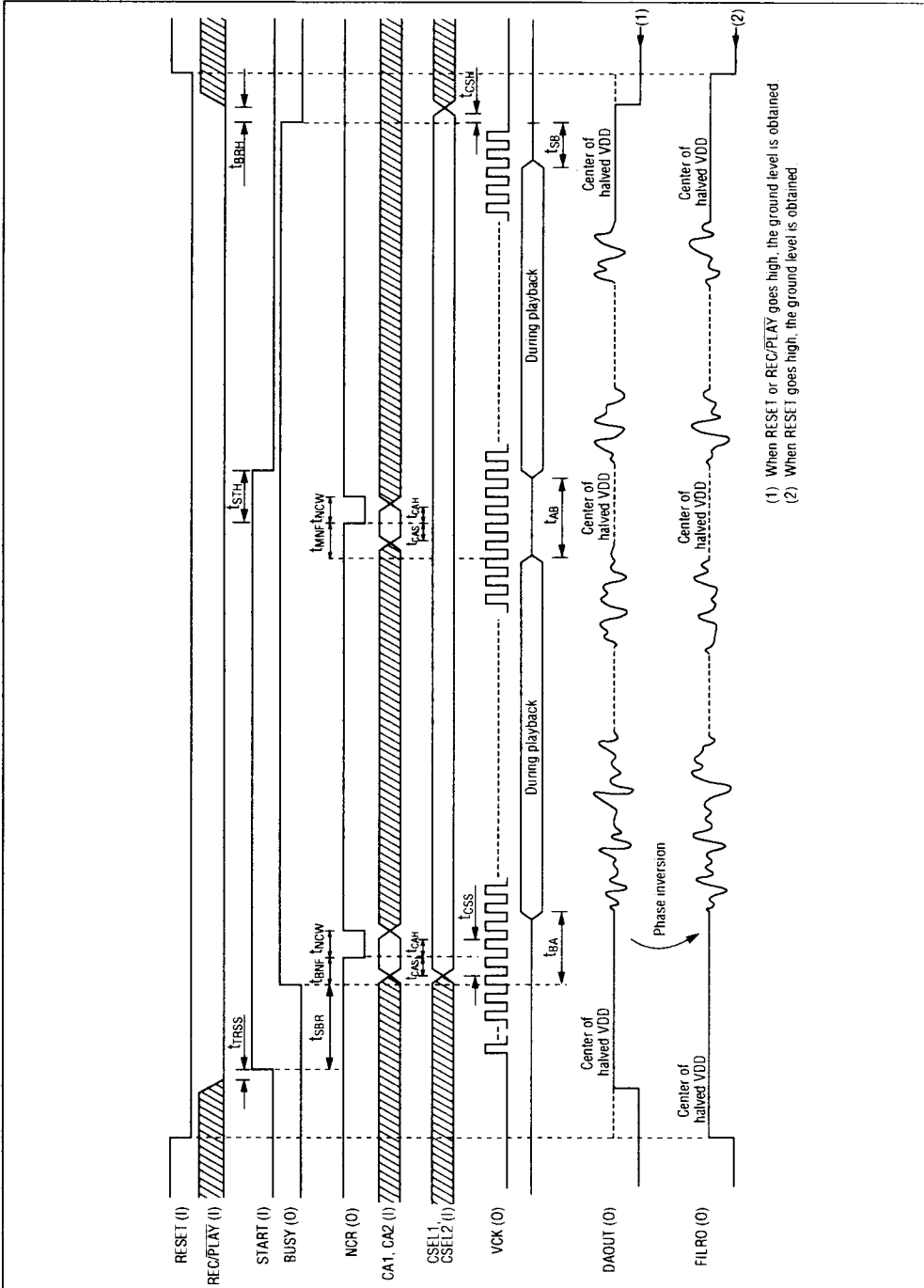

- (1) When RESET or REC/PLAY goes high, the ground level is obtained
- (2) When RESET goes high, the ground level is obtained

### 3. SRAM DRIVING TIMING

#### 3-1 SRAM driving at recording

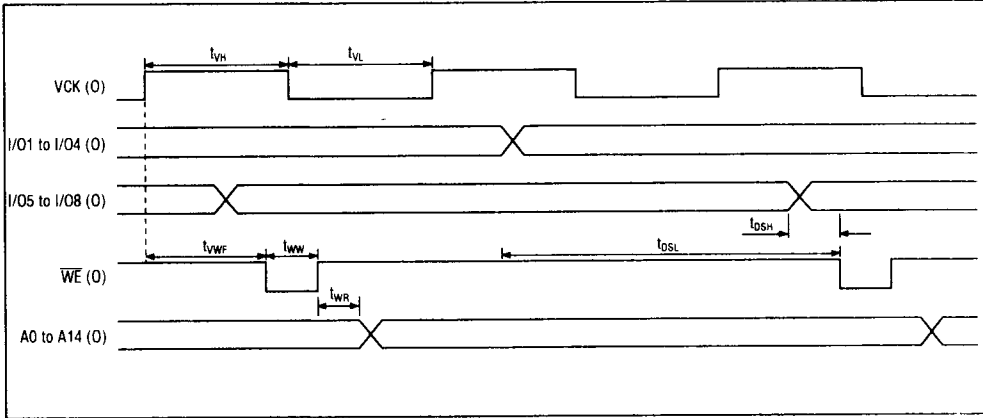

#### 3-2 SRAM driving timing at playback

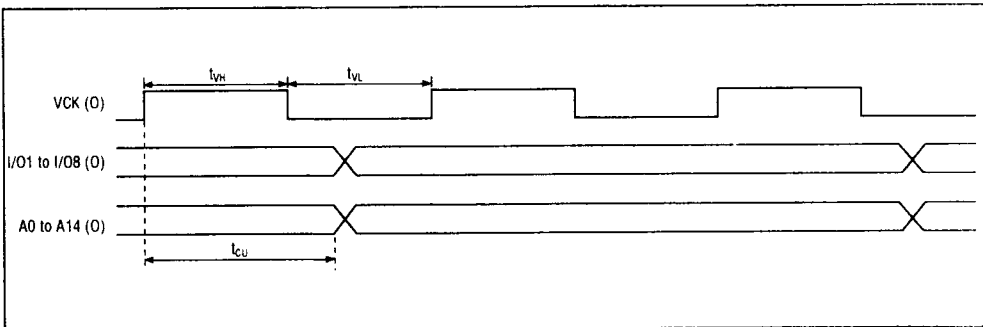

**PIN DEFINITION**

Pin name	I/O	Function
DVDD	I	Digital power supply pin
AVDD	I	Analog power supply pin
VDD'	I	Power supply pin
DVSS	I	Digital ground pin
AVSS	I	Analog ground pin
SG	O	Signal ground (SG) pin. Its output is at the halved VDD level. A capacitors is connected to stabilize the output.
SGC	O	A capacitor is connected for SG stabilization.
AMP1I	I	Inverted input pin of operational amplifier 1. The non-inverted input pins are connected to the signal ground (SG) in the insede.
AMP1O	O	Output pin of operational amplifier 1.
AMP2I	I	Inverted input pin of operational amplifier 2. The non-inverted input pins are connected to the signal ground (SG) in the insede.
AMP2O	O	Output pin of operational amplifier 2. It is connected to the built-in low-pass filter.
ADIN	I	Input pin of the AD converter
DAOUT	O	Output pin of the DA converter. It is connected to the built-in low-pass filter.
FILPO	O	Output reproduced waveforms that passed through the low-pass filter during playback.
FILRO	O	Outputs waveforms to be recorded that passed through the low-pass filter. Connect this pin to ADIN.
RESET	I	When this pin goes high, the power down mode is entered.
REC/PLAY	I	Selects either the recording mode or the playback mode. When this pin is high, the recording mode is entered.
START	I	When this pin goes high, recording or playback starts.
BUSY	O	Kept at the high level during recording or playback.
CSEL1	I	Selects the number of words to be registered together with CSEL2.
CSEL2	I	Selects the number of words to be registered together with CSEL1.
CA1	I	Specifies a channel when the number of words to be registered is set at 2 or 4.
CA2	I	Specifies a channel when the number of words to be registered is set at 4.
SAM	I	Selects a sampling frequency.
I01/I08	I/O	ADPCM data input/output terminal. Connected with SRAM I/O.
A0~A14	O	Address output terminal for SRAM.
CE <sub>1</sub> ~CE <sub>4</sub>	O	CE output terminal for 64K SRAM.
CE <sub>256</sub>	O	CE output terminal for 256K SRAM.

**PIN DEFINITION (Continued)**

Pin name	I/O	Function
WE	O	SRAM data write signal output terminal
ROM	I	When the H level is input, the data up to the end of the channel capacity is playback regardless of the recording time, and ordinarily set the L level.
XT	I	Input pin connected to an oscillator. External clocks are input through this pin.
$\overline{X}T$	O	Output pin connected to an oscillator. When using external clocks, place this pin in the open state.
VCK	O	Outputs the selected sampling frequency.
NCR	O	Outputs pulses when recording or multi-channel playback starts.
FCUTS	I	Selects a cutoff frequency of the low-pass filter.
TEST1	I	Test pin. Be sure to keep this pin at the low level.
TEST2	I	Be sure to keep this pin at the low level.

**FUNCTIONS**

- **Selection of the Number of Words to be Recorded and Specification of a Channel (CSEL1, CSEL2, CA1, and CA2)**

Use the CSEL1 and CSEL2 input pins to select 1, 2, or 4 as the number of words to be recorded. When 1 is selected, up to 256K bits are assigned as the memory capacity. When 2 is selected, up to 128K bits are assigned to

each channel as the memory capacity. When 4 is selected, up to 64K bits are assigned to each channel. It is possible to record in each channel until that channel's memory allocation is exhausted. Channels can be specified for the assigned memory capacities by the CA1 and CA2 input pins.

The following table shows the relationship between the number of words and channels:

CSEL2	CSEL1	Number of words	CA1	CA2	Channel	Channel Capacity
L	-	4 words	L L H H	L H L H	CH1 CH2 CH3 CH4	64Kbits are assigned to each channel
H	L	2 words	L H	- -	CH1 CH2	128Kbits are assigned to each channel
H	H	1 word	-	-	CH1	256Kbits

Use of memory is explained below for each specified channel.

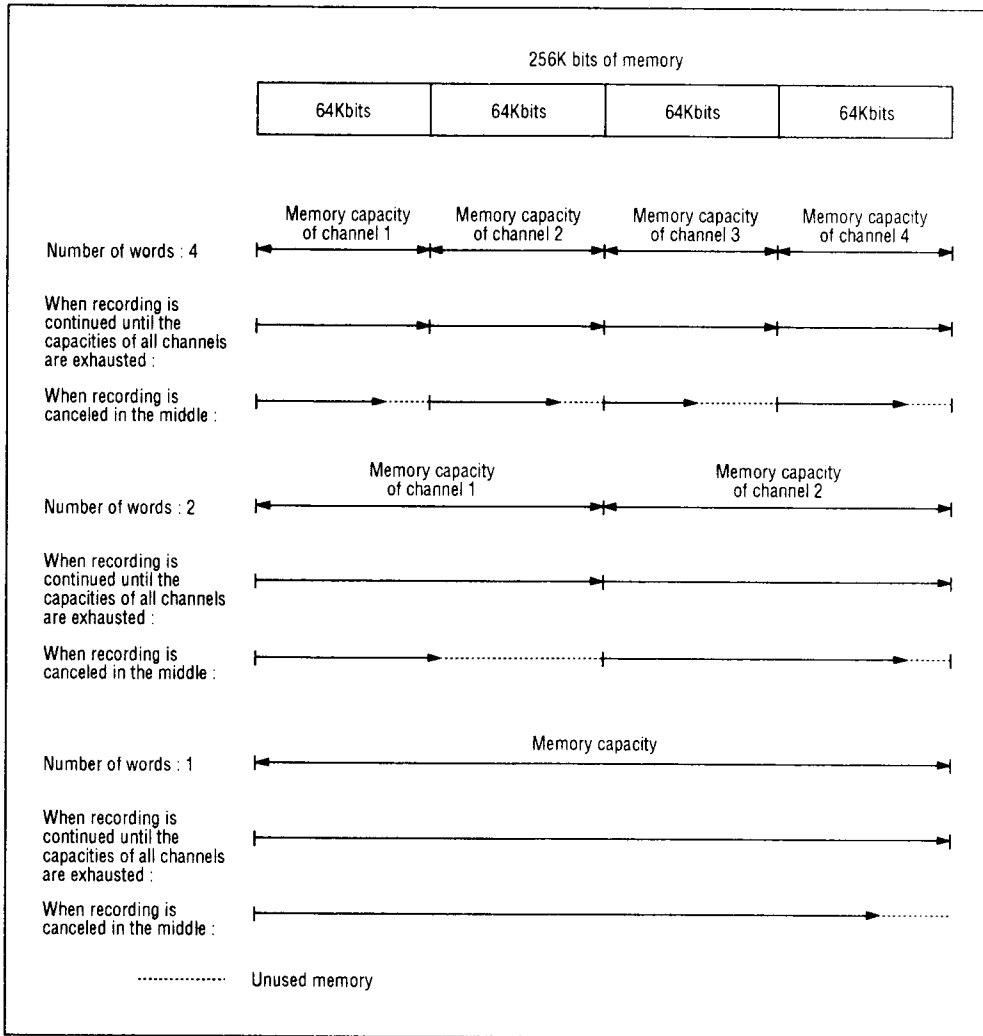

• **Selection of Sampling Frequency (SAM)**

the oscillator ( $f_{osc}$ ) and the sampling frequency ( $f_{sAMP}$ ) are as follows:

The relationships between the frequency of

SAM	L	H
$f_{sAMP}$	$f_{osc}/1024(4kHz)$	$f_{osc}/512(8kHz)$

( ) : The numbers in parentheses are true when the oscillator frequency is 4096 kHz.

• Selection of a Cutoff Frequency used by the Low-pass Filter (FCUTS)

Use the FCUTS pin to select a cutoff frequency used by the low-pass filter as follows (the cutoff frequency is proportional to the oscillator frequency.)

Sampling Frequency		FCUTS	
SAM	f <sub>SAMP</sub>	H	L
L	4kHz	2.3kHz	1.8kHz
H	8kHz	3.7kHz	2.8kHz

The oscillator frequency is 4096 kHz.

LOW-PASS FILTER FREQUENCY CHARACTERISTICS

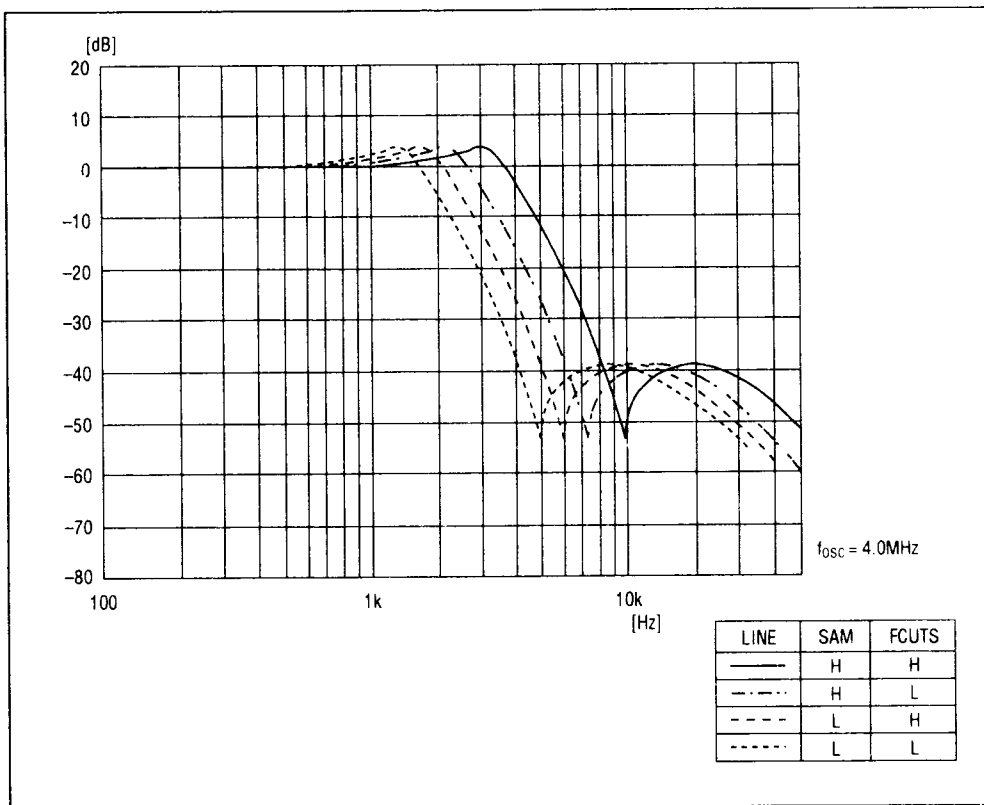

• **Recording and Playback**

1. Recording

Set the REC/ $\overline{\text{PLAY}}$  pin to a logic "1". Then select the number of words with the CSEL1 and CSEL2 pin and select a channel with the CA1 and CA2 pins.

To start recording, set the START pin high.

Recording is continued as long as the START pin is kept high. During recording, the BUSY output pin is at a "1". (See Figure 1)

When the capacity of the specified channel is exhausted, recording stops. At the same time, the BUSY pin goes low ("0"). (See Figure 2.)

2. Playback

Set the REC/ $\overline{\text{PLAY}}$  pin to a logical "0". Then select the number of words with the CSEL1 and CSEL2 pins and select a channel with the CA1 and CA2 pins.

To start playback, set the START pin high. Playback is continued for the time during which recording has been made. During playback, the BUSY output pin is high (See Figure 3.)

Repetitive playback is possible as long as the START input pin is kept high. For repetitive playback (by switching channels), see the explanation of the next channel request (NCR) function. During repetitive playback, the BUSY output pin is high as in the playback mode described above. (See Figure 4.)

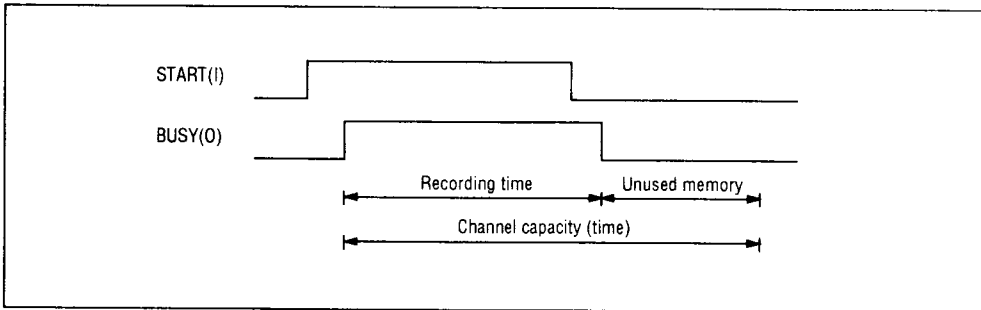

**Figure 1 Timing Chart When Recording is Stopped in the Middle**

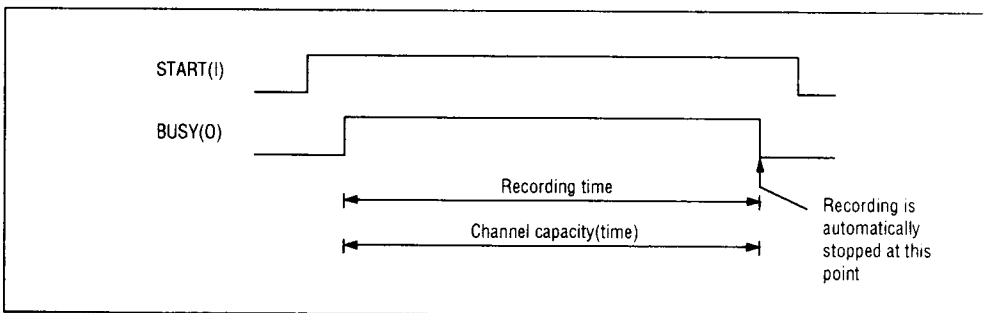

**Figure 2 Timing Chart When Recording is Continued Up to the End of the Channel Capacity**

**Note:** Since all bits of the stop bit are not controlled in the LSI, the recording time is extended up to 128 msec at a sampling frequency of 8 kHz. In addition, recording starts 20 to 30 msec after the START pin goes high.



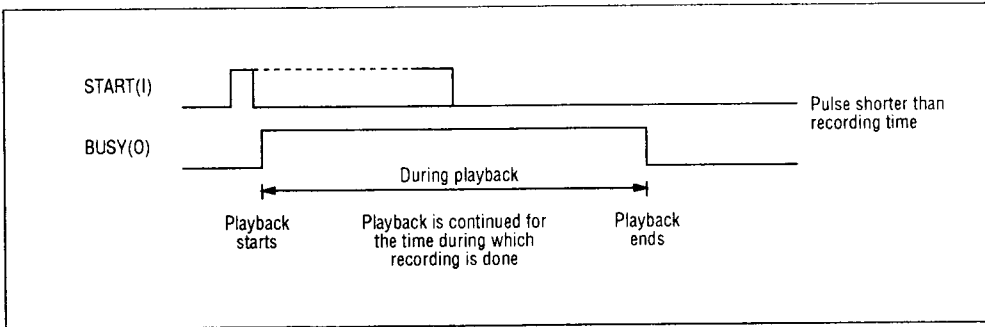

Figure 3 Timing Chart When Playback is Done Only Once

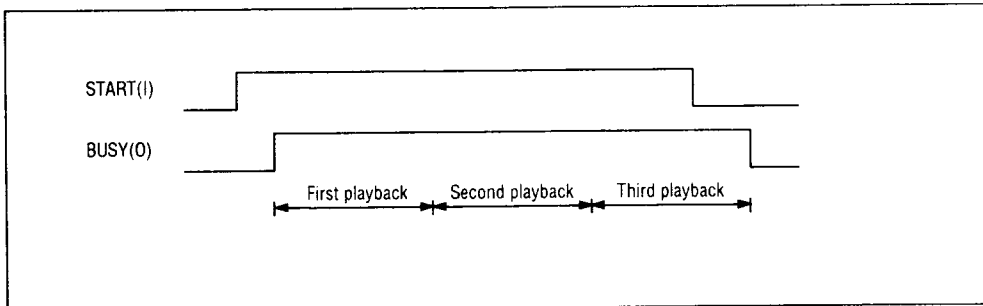

Figure 4 Timing Chart When Playback is Done Repeatedly

• **Next Channel Request (NCR) Functions**

The NCR pin output pulses as shown in the timing diagrams (Figures 7 and 8), when recording starts and playback starts for each word.

Repetitive playback is enabled as long as the START pin is kept high. When the NCR pin outputs a pulse, playback starts for a speci-

fied channel.

In the repetitive playback mode, the contents of each channels are stored in LSI on the falling edge of a pulse output from the NCR pin. When channels are switched by the CA1 and CA2 pins before the rising edge of a pulse from the NCR pin, therefore, the contents of multiple channels are played back continuously. (See Figure 9.)

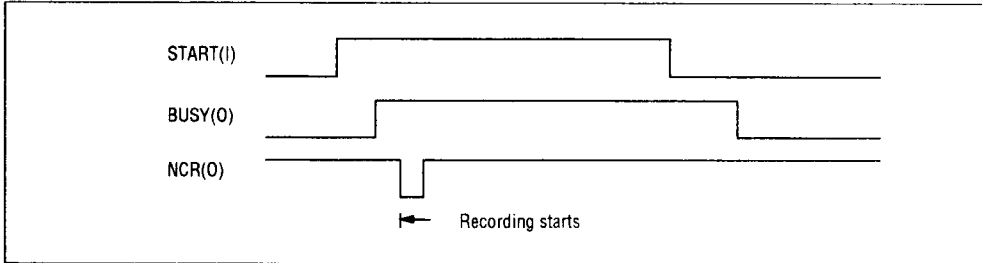

**Figure 7 NCR Pin Output during Recording**

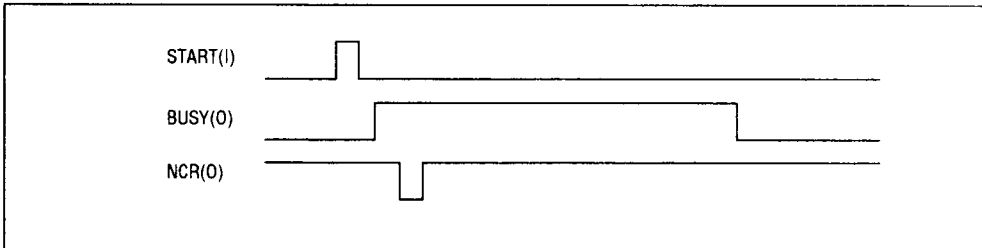

**Figure 8 NCR Pin Output during Playback**

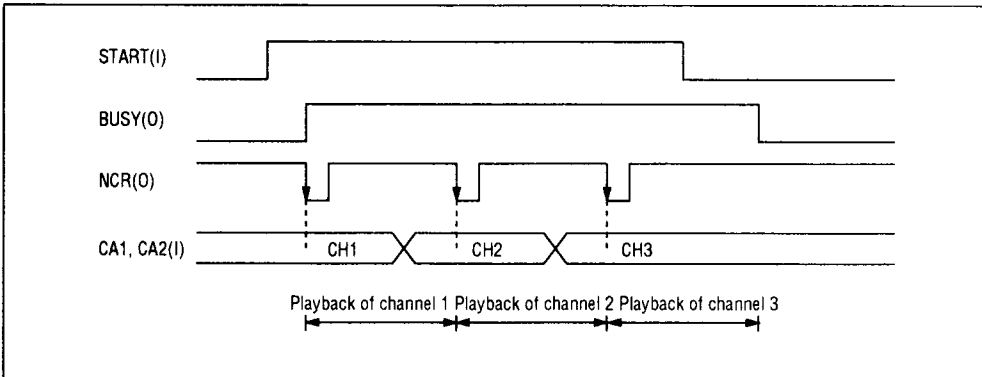

**Figure 9 Relationships between CA1 and CA2 Pin Pulses and NCR Pin Pulse during Continuous Channel Playback**

• **ROM Terminal Function**

When the H level is input to the ROM terminal, the voice data of the specified channel can be played back up to the end of the channel capacity irrespective of the recording time.

• **Power Down Functions**

This LSI can be powered down when the H level is input to the RESET terminal. If the RESET terminal is set to the L level even at the times other than recording or playback

one.

LSI status at power down  
(RESET terminal = H level)

- The LSI operation is stopped.
- The storage of the recording time is retained.

It takes 100 ms from the time when the RESET terminal is output to the L level and the analog circuit is in the operating status. (This time depends on the capacity values of the SG and SGC external capacitors.)

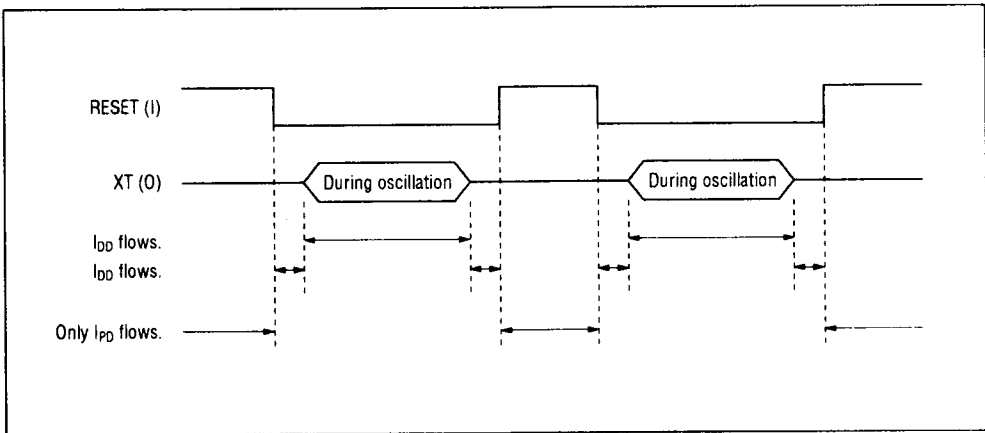

• Analog Circuit

1. Analog Input

This LSI incorporates two operational amplifiers for microphone output amplification. Each amplifier has an inverted input pin and an output pin. Non-inverted input is connected to the signal ground (SG) in the LSI.

For amplification to a speaker, the MSM6308GS requires an external amplifier. This amp is easily constructed from an operational amplifier configured as an inverting amp. The gain is adjusted with resistors in the op-amp's feedback loop. The relationship of these resistors to the amplification factors can be represented by the following expressions:

C1 and C2 in Figure 10 are coupling capacitors.

If using the Oki AMP20, adjust gain of the

amplifier so that the output of the AMP20 pin is about 0.6 x VDD (Vpp) due to the restrictions of input to the low-pass filter.

Connect the FILRO pin directly to the ADIN input pin of the A/D converter.

2. Analog Output

The output from the D/A converter is sent to the low-pass filter in the LSI. At the same time, the output is sent to the DAOUT pin.

Connect the amplifier for the speaker drive to the FILOP output pin of the low-pass filter.

The maximum output amplitude of the D/A converter is  $255/256 \times VDD$ . The D/A converter outputs stair step waveform in synchronization with the sampling frequency. To suppress noise, insert a capacitor between the DAOUT pin and the analog ground pin.

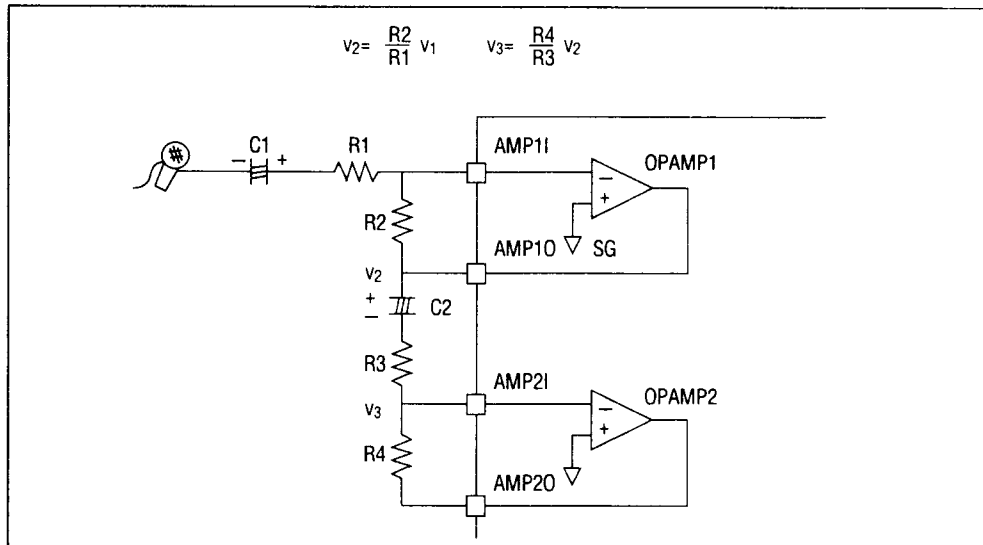

Figure 10 Analog Input Circuit and External Circuit

• **Relationship between the ADPCM Data and I/O1 to I/O8**

with the Oki Straight ADPCM adopted in the conventional MSM5205 and MSM6258.

The ADPCM data format is incompatible

Because 1-sample data consists of 4 bits, 2-sample is divided in 1 byte.

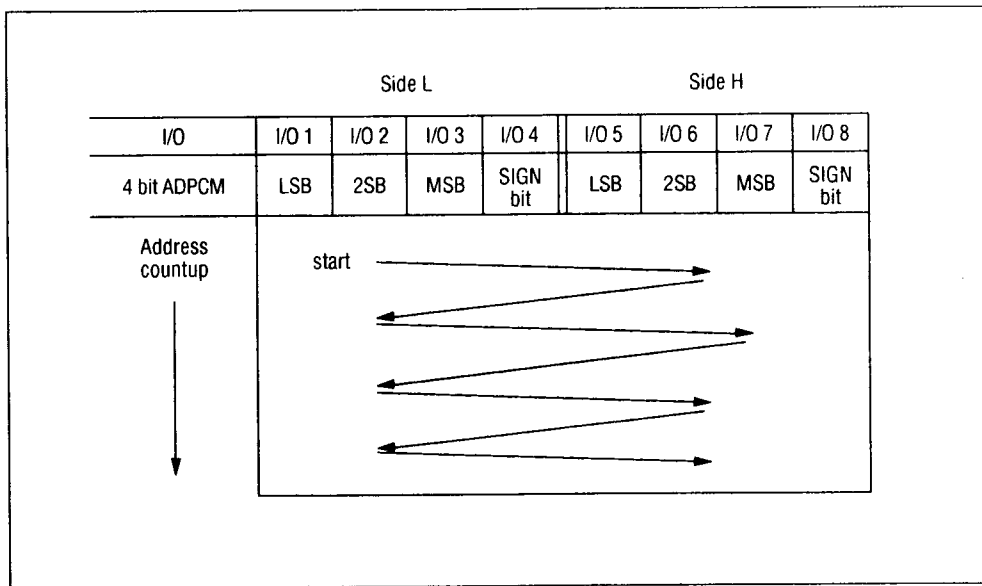

**Figure 11 Data Layout**

**Note:** The data layout of this LSI begins with the L side of the address and advances to the H side. The EPROM written from the analyzer manufactured by Oki (and its affiliated companies) is advanced from the H side of the address. When the LSI is connected with the corresponding EPROM, alternately connect the high-order four and low-order four I/O lines.

• **How to Connect the Oscillator**

For reference, the ceramic resonator manufactured by Murata Seisakusho for connecting the XT and  $\overline{XT}$  terminals is shown below.

Figure 11 shows how to connect the oscillator.

Ceramic resonator		Optimum load capacity value	
Model Name	Frequency(MHz)	C <sub>1</sub> (PF)	C <sub>2</sub> (PF)
CSA4.00MG	4.00	30	30
CSA4.09MG	4.09	30	30
CSA5.00MG	5.00	30	30
CSA6.00MG	6.00	30	30

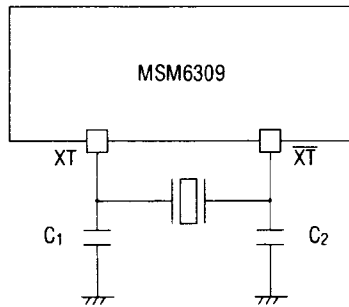

**Figure 12 Oscillator Connection**

EXAMPLE OF APPLICATION CIRCUIT

- Figure 13 shows an example of the application circuit when MSM6309 and 256K SRAM is used.
- Figure 14 shows an example of the application circuit when MSM6309 and four 256K EPROMs are used.

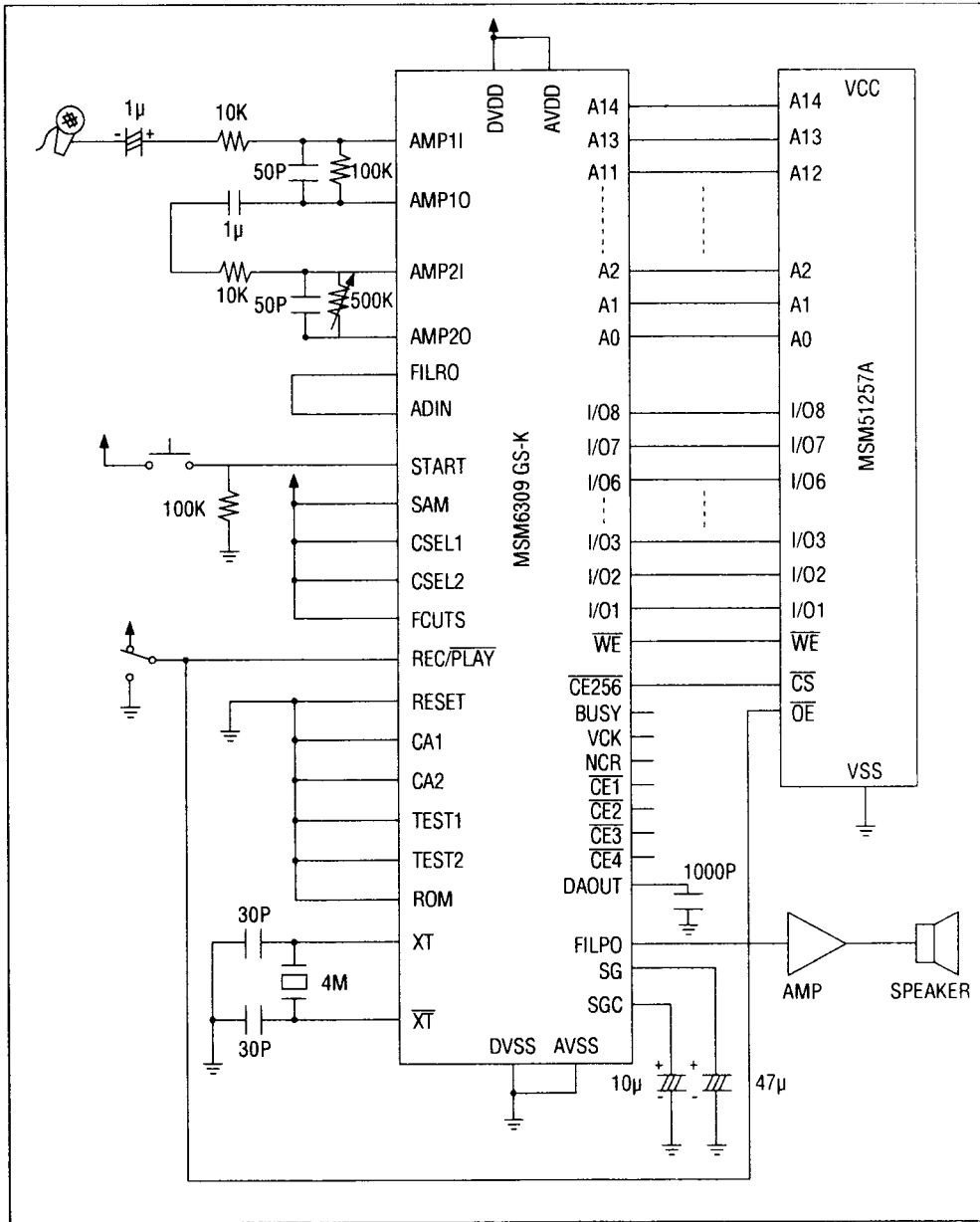

Figure13 Example of Application Circuit with 256K SRAM

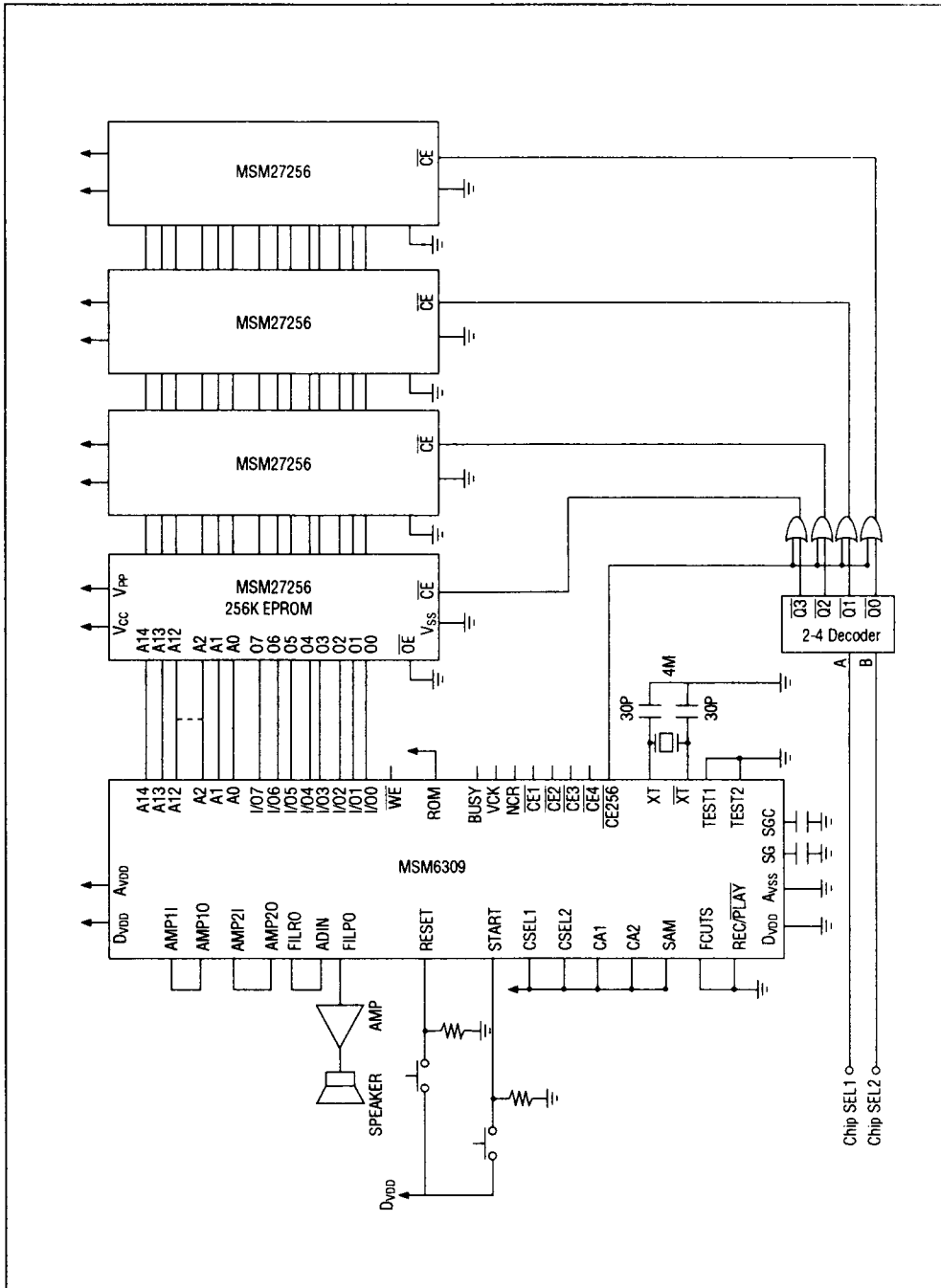

Figure 14 Example of Application Circuit with 256K EPROM